

# CONTAMINATION MONITORING PRODUCTS

**INSTALLATION,  
SERVICE AND  
MAINTENANCE MANUAL**

**ICS**  
**INLINE  
CONTAMINATION  
SENSOR**



EN

**PASSION  PERFORM**





# PRODUCT OVERVIEW

## ICS - Inline Contamination Sensor

The ICS automatically measures particulate contamination levels in various hydraulic fluids and is designed for industrial and mobile applications.

It is designed to be inline mounted directly to systems, where ongoing measurement or analysis is required and where space and costs are limited.

### Features & Benefits

- Inline mounting
- 3-channel contamination measurement
- Measures ISO 4406
- Space-efficient design
- Robust build quality
- Pressure max. 420 bar (6091PSI)
- Environmental Protection:
  - Mobile version: IP69K
  - Industrial version: IP67
- Impact Protection:
  - Mobile version: IK04
  - Industrial version: IK04
- 4-20mA analogue output (Industrial)
- RS485 Modbus RTU (industrial)
- CANbus (Mobile)



Industrial version



Mobile version



# DECLARATION OF CONFORMITY

## **CE** Declaration of Conformity

The products included in this Declaration are all variants of the following:

- Compatible with mineral oil/ synthetic fluids, offshore fluids.

For part codes see the Designation & Ordering Code (section 4.8)

Product Manufacturer:  
MP Filtri UK Ltd  
Keep House  
Vale Park  
Evesham  
Worcestershire  
WR11 1LB  
01386 258500  
sales-uk@mpfiltri.com

The products described are in conformity with the following directives:

2014/30/EU Electromagnetic Conformity

Certification Testing that has been carried out is in accordance with:

- DEF STAN 00-35 Part 3 issue 4 Environmental Test Methods
- BS EN 60068 range of standards covering environmental conditions
- BS EN 60529: 1992 + A2:2013 Degrees of Protection provided by enclosures (IP Code)
- BS EN 62262:2002 Degrees of Protection Provided for Electrical Equipment against External Mechanical Impacts (IK Code)
- BS EN 60721-3-4: 1995 Part 3: Classification of Groups of Environmental Parameters and their severities, Section 3.4

Date: September 2024

Signed:  
Kris Perks (Engineering Director) on behalf of MP Filtri UK Ltd



	Page
<b>PRODUCT OVERVIEW</b>	
Product Overview	1
EC Declarations of Conformity	3
Table of Contents	4
<b>GENERAL WARNINGS</b>	
<b>1 General warnings and information for the recipient</b>	<b>6</b>
1.1 General safety warnings	6
1.2 Dangers and Hazards that cannot be eliminated	8
1.3 Personal Protective Equipment	8
<b>TRANSPORT AND STORAGE</b>	
<b>2 Transportation and Storage</b>	<b>8</b>
2.1 Transportation and Handling Conditions	8
2.2 Storage	8
<b>GENERAL WARRANTY CONDITIONS</b>	
<b>3 Warranty, limits and exclusions</b>	<b>9</b>
3.1 Warranty on Recalibration	10
3.2 Download Area	11
<b>PRODUCT DOCUMENTATION</b>	
<b>4 Technical specification</b>	<b>12</b>
4.1 Performance	12
4.2 Electrical Interface	12
4.3 Physical Attributes	13
4.4 Fluid Characteristics	13
4.5 Environment	13
4.6 Wetted parts	13
4.7 Dimensions	14
4.8 Designation & Ordering code	15
<b>PRODUCT INSTALLATION</b>	
<b>5 Product Installation and General Operation</b>	<b>16</b>
5.1 Installation	16
5.2 Industrial Version: 4-20 mA installation	16
5.3 Customer PLC Program Example	17
5.3.1 Sequence	18
5.3.2 Detailed Sequence	19
5.3.3 ISO Coding	20
5.3.4 Status Values	21
5.4 Mobile version: CANbus installation electrical connections	21

# TABLE OF CONTENTS

	Page
<b>CANbus</b>	
<b>6 CANbus Configuration</b>	22
6.1 Recommended Configuration	22
<b>7 CANbus Operations</b>	22
7.1 CANbus settings	22
7.2 Operation	22
7.3 Message: Result Codes	23
7.4 Message: Status codes	23
<b>MODBUS</b>	
<b>8 MODBUS Configuration</b>	24
8.1 Overview	24
8.3 Electrical Connection	24
<b>9 MODBUS Operation</b>	25
9.1 Modbus settings	25
9.2 Communications check	25
9.3 Result format	25
9.4 Result codes	25
9.4.1 ISO 4406	25
9.4.2 Test Status	26
9.5 Test Completion	26
<b>REFERENCE</b>	
<b>10 Reference</b>	27
10.1 Modbus Node Addressing	27
10.2 Modbus settings	27
10.3 General Description	27
10.4 Modbus registers	27
10.5 Modbus Register Numbering	27
10.6 Modbus Register Table	28
10.7 Register Functions	30
10.8 Status Register	31

# 1. General warnings and information for the operator

## 1.1 General safety warnings

Do not operate, maintain or carry out any procedure before reading this manual. Any individual operating the unit shall wear the following Personal Protective Equipment:

- Protective eyewear
- Safety shoes
- Gloves
- Overalls (or other suitable protective clothing)

Before carrying out any machine installation procedures and/or before use, one should scrupulously follow the instructions listed in this manual. Moreover, it is necessary to comply with the current regulations related to occupational accident prevention and safety in the workplace.

Notices aimed at the prevention of health hazards for personnel operating the machine are highlighted in this document with signs having the following meaning:

It relates to important information concerning the product, its use or part of this documentation to which special attention must be paid



NOTE

It means that failure to comply with the relevant safety regulations may result in mild injury or property damage.



CAUTION

It means that failure to comply with the relevant safety regulations may result in death, serious injury or serious property damage.



DANGER

Failure to comply with the relevant safety regulations may result in death, serious injury or serious property damage.



# GENERAL WARNINGS

To allow rapid identification of the employees who must read this manual, definitions have been used with the following meaning:

OPERATOR	This is any individual whose task is to use the machine for production purposes. The operator is aware of all the measures taken by the machine manufacturer in order to eliminate any source of injury risk in the workplace and takes into account the operational constraints.
PERSONNEL INVOLVED IN SLINGING AND HOISTING OPERATIONS	This is any individual whose task is to handle the machine or parts of it. Personnel involved in slinging and hoisting operations are aware of the issues regarding the safe transfer of machinery or parts of it and, therefore, uses appropriate lifting equipment, following the instructions provided by the product manufacturer.
MACHINE SETTER	This is any individual whose task is to set up the machine for its operation. The machine setter is aware of the measures taken to eliminate all sources of injury risks in the workplace and takes into account the operational constraints. The machine setter takes all the appropriate precautions in order to operate in utmost safety conditions.
MAINTENANCE TECHNICIAN	This is any individual whose task is to carry out maintenance activities on the machine. The maintenance technician is aware of the possible danger situations that may arise and takes the appropriate precautions in order to eliminate the risks of accidents in the workplace.
ELECTRICIAN	This is any individual whose task is to carry out maintenance activities on the electrical wiring of the machine. The electrician is aware of the possible danger situations that may arise and takes the appropriate precautions in order to eliminate the risks of accidents in the workplace.

The unit shall be taken out of service and/or dismantled in accordance with the current regulations in force in the country where the machinery is installed



## 1.2 Dangers and hazards that cannot be eliminated

- Risk of hydraulic injection injury
- Burn risk because of high temperatures
- Accidental oil leaks with consequent risk of slipping
- Hose breakage and resulting lubricant loss
- With oil temperatures exceeding 40/45 °C (100/115 °F), it is vital to be extremely careful when handling the unit. Avoid direct contact with hot oil.

AFTER USE - ALL EQUIPMENT SHOULD BE ALLOWED TO COOL PRIOR TO HANDLING

## 1.3 Personal protective equipment

When operating the unit, personnel must be wearing safety shoes, gloves and goggles/safety glasses. In general, the PPEs to be used according to the activities on the machinery are listed in the following table:

ACTIVITY	PPE
Ordinary operation	Shoes, gloves, goggles, overall
Planned maintenance	Shoes, gloves, goggles, overall



# 2. Transportation and Storage

## 2.1 Transportation and handling conditions

The unit is shipped in a cardboard box with appropriate protective packaging and these should be recycled accordingly where possible. The packed weight of the ICS and accessories is 1.0 kg (2.2 lbs)

## 2.2 Storage

The unit should be stored in a suitable location away from the production area when not in use. The unit should be stored with the caps provided on the ports. This location should not impede any other production or personnel.

# WARRANTY

## 3. Warranty, Limitations and Disclaimers

MP Filtri warrants that the products that it manufactures and sells will be free from defects in material, workmanship & performance for a period of 12 months from the date of shipment.

### Hardware/Firmware

Should the hardware prove defective during the warranty period, MP Filtri, at its discretion, will either repair the defective product or replace it with an equivalent product in exchange for the defective unit without charge for parts, labour, carriage and insurance.

### Software

MP Filtri warrants that software will operate substantially in accordance with its functional specification for 12 months from date of shipment provided that the integrity of the operating environment has not been compromised through misuse, inappropriate handling, abnormal operating conditions, neglect or damage (unintentional or otherwise) or the introduction of third party product (software or hardware) that in any way conflicts with the MP Filtri product.

### Eligibility

This warranty extends to the original purchaser only or to the end-user client of a MP Filtri authorised affiliate.

### How to obtain service?

To obtain service under the terms of this warranty, the customer is required to notify MP Filtri before the expiration of the warranty period and to return the item in accordance with MP Filtri product return policy. Any product returned for warranty repair must be accompanied by a full fault report specifying the symptoms and the conditions under which the fault occurs. Should MP Filtri incur additional cost as a result of a failure to complete the appropriate paperwork, an administrative charge may be levied.

### Exclusions

This warranty shall not apply to any defect, failure or damage caused by improper use or improper or inadequate care. MP Filtri shall not be obligated to provide service under this warranty if:

- a) Damage has been caused by a failure to make a full and proper inspection of the product (as described by the documentation enclosed with the product at the time of shipment) on initial receipt of the product following shipment;
- b) Damage has been caused by the attempts of individuals, other than MP Filtri staff to repair or service the product;
- c) Damage has been caused by the improper use or a connection with incompatible equipment or product including software applications.

### Charges

Under cover of this warranty, MP Filtri will pay the carriage and insurance charges for the shipment of defective product back to site of manufacture and for its return to the client's original site of despatch except when:

- a) MP Filtri product return policy has not been followed.
- b) Product failure is caused by any of the exclusions described above, when the customer will be liable for the full cost of the repair (parts and labour) plus all carriage and insurance costs to and from MP Filtri premises.
- c) The product is damaged in transit and a contributory cause is inadequate packaging. It is the customer's responsibility to ensure that the packaging used to return equipment to MP Filtri is the same, or has equivalent protective qualities, to that used to ship the product to the customer in the first instance. Any damage resulting from the use of inadequate packaging will nullify MP Filtri

obligations under this warranty. Should the customer's product be damaged in transit following a repair at MP Filtri site, a full photographic record of the damage must be obtained (packaging and the product) to support any claim for recompense. Failure to present this evidence may limit MP Filtri obligations under this warranty.

THIS WARRANTY IS GIVEN BY MP FILTRI IN LIEU OF ANY OTHER WARRANTIES, EXPRESS OR IMPLIED, INCLUDING BUT NOT LIMITED TO ANY IMPLIED WARRANTY OF MERCHANTABILITY, NON INFRINGEMENT OR FITNESS FOR A PARTICULAR PURPOSE. MP FILTRI LTD SHALL NOT BE LIABLE FOR ANY SPECIAL, INDIRECT, INCIDENTAL OR CONSEQUENTIAL DAMAGES OR LOSSES ( INCLUDING LOSS OF DATA), WE SPECIFICALLY DISCLAIM ANY AND ALL WARRANTIES TO CUSTOMERS OF THE CUSTOMER. THE CUSTOMER'S SOLE REMEDY FOR ANY BREACH OF WARRANTY IS THE REPAIR OR REPLACEMENT, AT MP FILTRI DISCRETION, OF THE FAILED PRODUCT.

MP Filtri Ltd maintains a policy of product improvement and reserves the right to modify the specifications without prior notice.

### **3.1 Warranty on Recalibration**

The ICS is guaranteed for 12 months upon receipt of the product, subject to it being used for the purpose intended and operated in accordance with this User Guide.

MP Filtri will only verify the accuracy of the ICS if the unit is recalibrated every 12 months.

MP Filtri will not be held responsible for any items returned as such.

Ensure that the ICS is packed appropriately for transportation.

# PRODUCT DOCUMENTATION

## 3.2 Download Area

Please scan the QR codes below to get updated electronic version of the related document.

**CONTAMINATION MONITORING PRODUCTS** General catalogue

Download PDF

*Scan or click me!*

**CMP View Software** Quick Guide

Select your language and download PDF

*Scan or click me!*

**CMP View Software** Software multilingual

Download Software



*Scan or click me!*

## 4. Technical Specification

### 4.1 Performance

Technology	LED-based Light Extinction Automatic Optical Contamination Sensor
Particle Sizing	>4, 6, 14 µm
Analysis range	ISO 4406
Calibration	Each unit individually calibrated with ISO Medium Test Dust (MTD) based on ISO 11171, on equipment certified by I.F.T.S. ISO 11943
Accuracy	±1/2 ISO code for 4, 6, 14 µm

### 4.2 Electrical interface

Supply Voltage	Industrial version: 24v DC +/- 20% Mobile version: 9-36v DC
Power Consumption	<1.5W
Test Time	Standard factory setting: 2 minutes
Communication Options	Industrial Version: 4-20mA Time Multiplexed; RS485 Modbus RTU Mobile Version: CANbus

Please note Comms protocols are covered in Section 5.

# TECHNICAL SPECIFICATION

## 4.3 Physical attributes

Dimensions	Industrial: 58 mm (2.3 inches) (W) x 50 mm (2 inches) (D) x 68 mm (2.7 inches) (H) Mobile: 58 mm (2.3 inches) (W) x 50 mm (2 inches) (D) x 76 mm (3 inches) (H)
Hydraulic connection	Inline mounting
Weight	0.9 kg (2lbs)
IP Rating	Industrial version: IP67; Impact Protection IK04 Mobile version: IP69K; Impact Protection IK04

## 4.4 Fluid characteristics

Fluid compatibility	M version - mineral oils, synthetic fluids
Viscosity	≤ 1000 cSt
Fluid temperature	Industrial version: From -25°C (-13°F) to +80°C (+176°C) Mobile version: From -25 °C (-13°F) to +100°C (+212°C)
Operating flow rate	20 to 400 ml/minute
Minimum pressure	0.5 bar (6091PSI)
Maximum pressure	420 bar (6091PSI)

## 4.5 Environment

Ambient working temperature	Industrial version: From -10°C (+14°F) to +55°C (+131°F) Mobile version: From 0°C (+32°F) to +50°C (122°F)
Electrical load (Mobile version only)	In accordance with ISO 16750-2
Mechanical load (Mobile version only)	In accordance with ISO 16750-3

## 4.6 Wetted Parts

M Version
M316 Stainless Steel
Sapphire (Al <sub>2</sub> O <sub>3</sub> )
FPM
PTFE

## 4.7 Dimensions

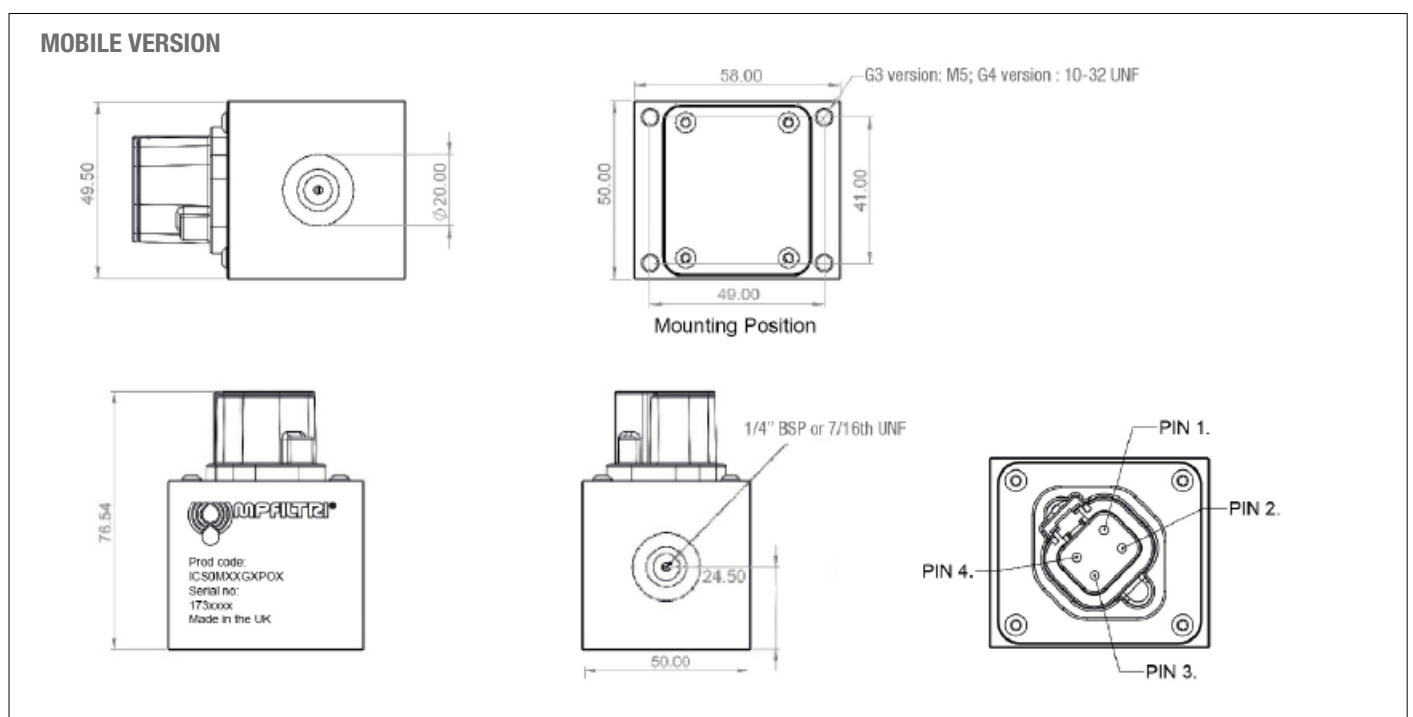
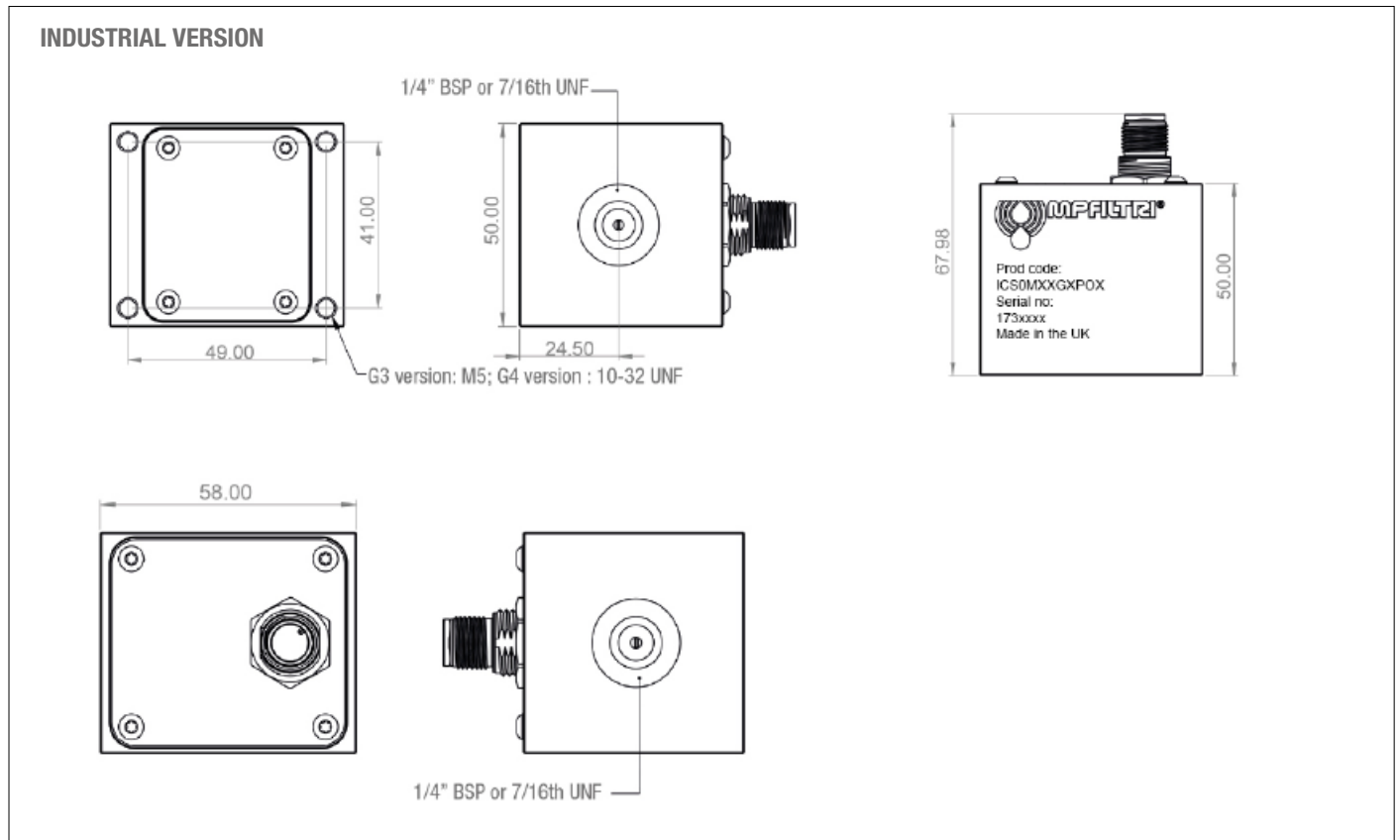



# TECHNICAL SPECIFICATION

## 4.8 Designation & Ordering code

ICS AUTOMATIC CONTAMINATION MONITORING SENSOR	
Contamination Monitoring Product	Configuration example: ICS 0 M 0 0 G3 P01
<b>ICS</b> Inline Contamination Monitoring Sensor	
Sensor options	
<b>0</b> Standard	
Fluid compatibility	
<b>M</b> Mineral oil and synthetic fluids	
Communication protocol	
<b>0</b> 420 mA	
<b>1</b> RS485 Modbus RTU	
<b>2*</b> CANBUS	
Electric connection	
<b>0</b> M12 4pin	
<b>1*</b> DTP10-4P	
Port Options	
<b>G3</b> 1/4" BSPP Female	
<b>G4</b> 7/16th UNF Female	
Design Ref	
<b>P01</b> Standard	

\* Mobile version only

## 5. Product Installation and General Operation

### 5.1 Installation

Each ICS supplied consists of the following:

- 1 x ICS as specified
- 1 x Installation kit, containing:
- 1 x ICS\* Version as specified
  - 2 x Hard copy of calibration certificate
  - 1 x Datastick with installation guide and user manual

### 5.2 Industrial Version: 4-20mA installation

Connectors are 4pin M12, "A-Coded". The connector on the device has the male pins. The diagram below is a view from end of the cable plug not the ICS socket.

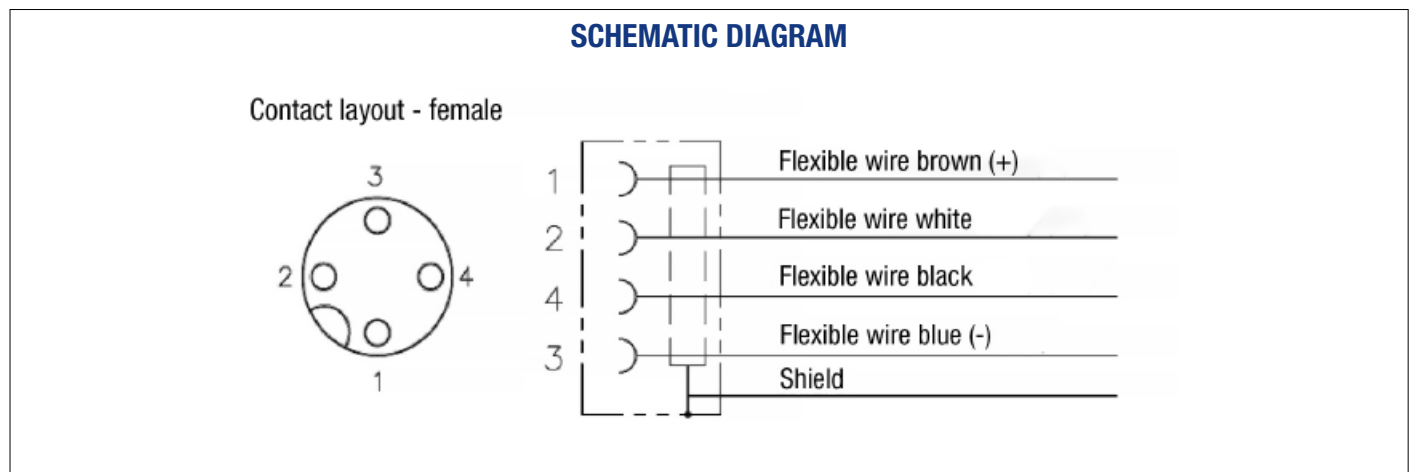

The 0V is connected internally to the case as well as the shield.

Signal	Pin	Colour	Comment
+24V	1	Brown	DC POWER
4-20mA	2	White	CURRENT SOURCE
0V	3	Blue	0V is internally connected to the metal block by design
START+	4	Black	Connect to +24 during test time

# PRODUCT INSTALLATION

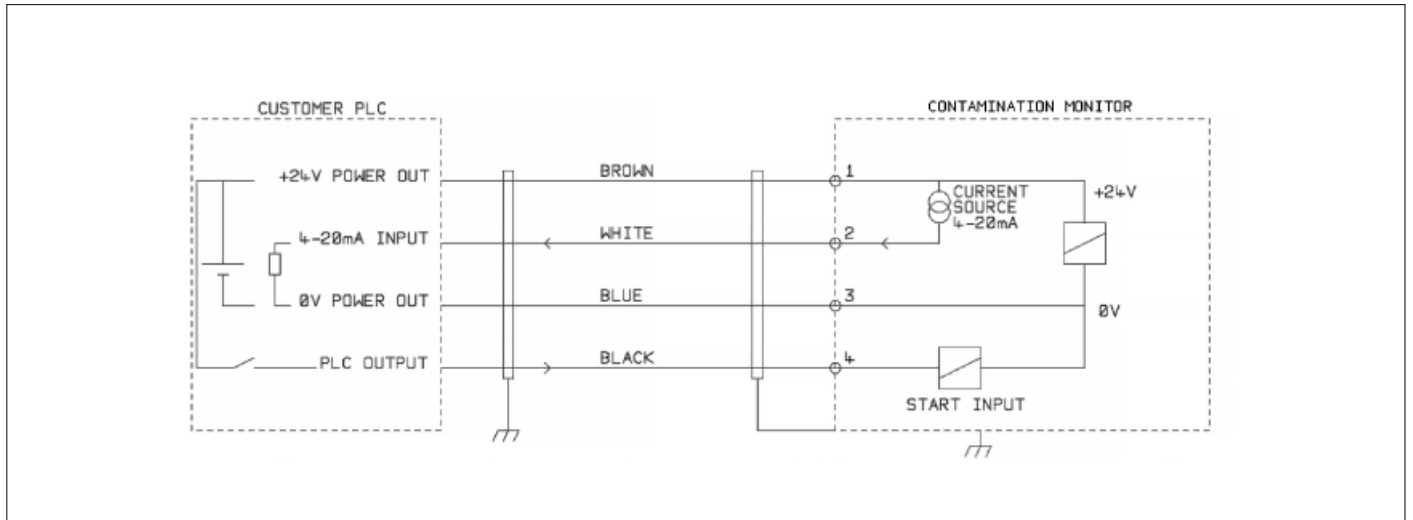

The cable + connector needs to be a shielded 4way, A-coded, female pin type. An example could be TE 2273099-1. Alternatively a re-wireable type can be used.

## 5.3 Customer PLC Program Example

The customer PLC communicates with the unit by energizing a switched START signal and reading the results result from a 4-20mA current signal

- The START signal duration controls the test period
- The 4-20mA signal is time-multiplexed, that is, the parameters are output in a timed sequence

We report the 4, 6 and 14um ISO codes. We also include a function to report the status of the unit (OK, ERROR, TESTING etc) but decoding this is optional. An example test sequence is shown below, the highlighted sections may not be required for the application.

### 5.3.1 Sequence

#### If pump not running

- Turn on pump
- Wait until flow is stable and piping flushed, perhaps 60 seconds

#### If ICS not powered

- Turn on ICS power
- Wait >3 seconds
- Option: read status signal
- Turn on START signal
- Wait 300 seconds for testing (example)
- Option: check status
- Turn off START signal
- Wait 1 second
- Read 4-20mA signal.  $ISO4 = (mA \times 2) - 8$
- Wait 2 seconds
- Read 4-20mA signal.  $ISO6 = (mA \times 2) - 8$
- Wait 2 seconds
- Read 4-20mA signal.  $ISO14 = (mA \times 2) - 8$
- Option: check status
- Wait 2 seconds
- Read status

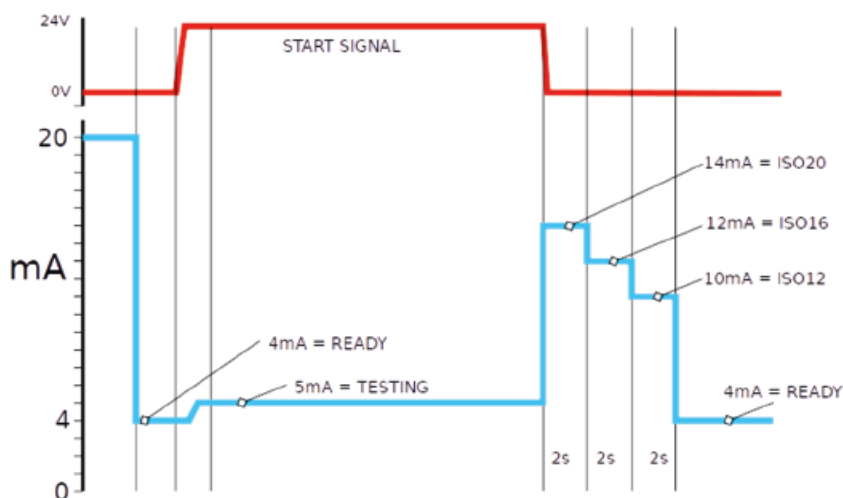

# PRODUCT INSTALLATION

## Optional

- The customer program can also read and decode the STATUS signal
- The flow can be continuous
- The power can be continuous

### 5.3.2 Detailed Sequence

Duration (seconds)	Device Action	START Signal	4-20 mA	PLC Responsibility
	Power off	OFF		Start pumps, flow etc.
	Power on	OFF		Apply power
<3	(ICS starts up, self tests)	OFF		
	Output status value	OFF	STATUS	Optional: Check status
>10 s if required perhaps 60 seconds		OFF	STATUS	If flow is not continuous, ensure machine operation is stable, and there has been time for old fluid to be flushed from the system
	Start testing	ON	TESTING	Turn on START signal Start test timer
Customer defined, perhaps 300 seconds	Count particles	ON	TESTING	Test timer running
< 0.1s	Calculate result codes	OFF		Test timer finished Turn off START signal Start 1.0 second timer
2.0 s	Output 4 µm result	OFF	ISO (4um)	Timer finished: Read 4 µm result Start 2.0 second timer
2.0 s	Output 6 µm result	OFF	ISO (6um)	Timer finished: Read 6 µm result Start 2.0 second timer
2.0 s	Output 14 µm result	OFF	ISO (14um)	Timer finished: Read 14 µm result Start 2.0 second timer
	Output status	OFF	STATUS	
				Start another test or wait or power off etc

### 5.3.3 ISO Coding

$$\text{ISO CODE} = 2 \times (\text{mA} - 4) = (2 \times \text{mA}) - 8$$

$$\text{(reverse: mA} = 4.0 + \text{ISO}/2)$$

CODE	Nominal Current (mA) +/- 0.2mA
0	4.0
1	4.5
2	5.0
3	5.5
4	6.0
5	6.5
6	7.0
7	7.5
8	8.0
9	8.5
10	9.0
11	9.5
12	10.0
13	10.5
14	11.0
15	11.5
16	12.0
17	12.5
18	13.0
19	13.5
20	14.0
Saturation	17.0
No value	18.0
Reserved	19.0
Reserved	20.0

Note: any value above 14.0 up to but not including the 17.0

# PRODUCT INSTALLATION

## 5.3.4 Status Values

- It is optional to read these
- These functions may be changed or removed before final project release

STATUS	Nominal Current (mA) +/- 0.2mA	When Output
OK – Ready	4	After power-up or after test
Testing	5	During test
Fault: LED fail or blocked	6	After power up or during test or after test
Not ready	20	During power-up and self- test
	11-19	Reserved for future use

## 5.4 Mobile version: CANbus installation electrical connections

### ICS-M Connection

DTP10-4 Pin		
Signal	Pin	Comment
0V = CHASSIS	1	0V is internally connected to the metal block by design
+12 / +24	2	Product is designed for +12V and +24V automotive / mobile equipment supplies
CANL	3	CANbus termination must be done externally at each end of the CANbus, or using a through terminator if the ICS at one end
CANH	4	

The ICS requires a DC power supply and the two CAN-bus signals CANL and CANH. The numbers shown are the pin numbers of the circular connector that plugs into the ICS.

- The DC voltage is typically 24V, but can be 9-36V
- Twisted pair cable should be used for the CAN-bus signals, for cable lengths over a few meters
- CAN-bus requires the network to be terminated at each end. This must be done externally to the ICS
- The CAN-bus signals CANL and CANH are referred to the system 0V supply

These should stay within the common mode range allowed by the ISO-11898-4 CAN-bus standard relative to the ICS 0V connection. This range is -2V to +7V.

This can be normally be ensured by connecting together the ICS 0V and the 0V of the CAN-bus controller. The `CAN 0V` wire shown indicates this link.

## 6. CANbus Configuration

### 6.1 Recommended Configuration

All Mobile versions are preset to CANbus communications protocol. The default 29 bit format is designed to be compatible with the J1939 standard. It should also be possible to use the ICS with any system that permits arbitrary raw CAN-bus 2.0B identifiers to be received.

## 7. CANbus Operations

### 7.1 CANbus settings

CANbus physical layer	ISO 11898
Protocol type	CAN 2.0B (29 bit identifiers)
Baud	Preset: 250k
Identifier	250k

### 7.2 Operation

At the end of each set test interval (e.g. 2 minutes) the ICS will emit a CAN 'Result Codes' message using the set CAN identifier (0x18FFB53F using hexadecimal notation). So a typical CAN message might be:

	Byte							
	1	2	3	4	5	6	7	8
0x18FFB53F	12	8	2	1*				

\* Test status ready



# CANBUS

## 7.3 Message: Result Codes

This message is transmitted after each test.

The test result is expressed as a set of codes in the selected Test Format (ISO4406). The test result message is always 8 bytes long, with the result codes packed as follows:

FORMAT	ISO 4406
Byte	Code
1	4µm(c)
2	6µm(c)
3	14µm(c)
4	Status Code

## 7.4 Message: Status codes

This is a number used to indicate the current state of the ICS, or a fault code in the case of a problem being detected. The codes are listed in the STATUS CODE parameter Table below. This allows a system to remotely monitor the ICS operation, if desired, allowing more specific diagnostics.

Value	Function	Comment
0	Not ready	Unit is powering-up, or there is some problem
1	Ready	Ready to start a test
2	Testing	Test in progress
3	Waiting	Waiting between tests
128	Fault - Optical	LED failure / sensor blocked / filled with air
129	Fault - Flow Low	Flow too low for reliable test
130	Fault - Flow High	
131	Fault Logging	Fault with data logging

## 8. MODBUS Configuration

### 8.1 Overview

- Connect the ICM to RS485 port on your Modbus controller (PC or PLC)
- Connect 24V DC power supply
- Configure your controller as a Modbus RTU master, addressing slave address 204

Modbus is a simple, popular, open and freely available protocol for industrial communication.

The ICS incorporates a serial data connection using the Modbus protocol for comprehensive remote control and monitoring.

The responsibilities of a customer implementation can be as simple as continuously reading the current contamination level from test result registers.

### 6.2 Electrical Connection

This user guide assumes a Modbus network consisting of a Controller (PC or PLC) connected to a single ICS. It is also possible to share the network with other devices, providing these are allocated separate node addresses.

More details can be provided on request.

The ICS requires a DC power supply and the two Modbus RS485 signals.

- The DC voltage is typically 24V
- Twisted pair cable should be used for the RS485 signals, for cable lengths over a few meters

## 9. MODBUS Operation

### 9.1 MODBUS settings

Protocol type	RTU (not ASCII)
Data bits	8
Stop bits	1
Parity	Required, Even
Baud	Auto-sensing 1200-115200
Signalling	RS485
Node Address	204

### 9.2 Communications check

You should be able to read the product ID code from register 0 (from Modbus node address 204). The product ID code is the value 54241 (decimal) or D3E1 (hexadecimal).

### 9.3 Result format

The ICS presents results in ISO 4406 format.

### 9.4 Result codes

The most recent measurements are presented as numeric codes (i.e. numbers) according to the the selected TEST FORMAT.

These codes can be read from registers 56-58, as per the table below:

Register	ISO4406 code
56	$\geq 4\mu$
57	$\geq 6\mu$
58	$\geq 14\mu$

#### 9.4.1 ISO 4406

ISO 4406 defines a set of code values to represent ranges of counts of particles greater than the nominated sizes of  $\geq 4$ ,  $\geq 6$  and  $\geq 14\mu\text{m(c)}$ . The ICS can display codes from 0 to 24.

### 9.4.2 Test Status

A test status code is available in register 30. This contains a number indicating the current state of the ICS.

This allows a system to remotely monitor the ICS operation, if desired, allowing more specific diagnostics.

Value	Function	Comment
0	Not ready	Unit is powering-up, or there is some problem
1	Ready	Ready to start a test (User has not set tests to occur automatically)
2	Testing	Test in progress
3	Waiting	Waiting between tests (User has set a non-zero test interval.)
128	Fault optical	LED failure / sensor blocked / filled with air
129	Fault flow low	Flow too low for reliable test. (Or fluid is totally clean (no particle counts). Flow alarm can be turned off by user if this is a problem, for example cleaning rigs.)
130	Fault flow high	

### 9.5 Test Completion

The TEST COMPLETION is indicated by register 36. This contains a number between 0 and 1000 indicating the test progress.

## 10. Reference

### 10.1 Modbus Node Addressing

Modbus requests are sent to ICS node address 204. If there is only one ICS on network segment the 'Permanent Address' of 204 can be used.

This is not part of the Modbus specification (and in fact violates it). The ICS will always respond on node address 204, in addition to the other set value.

### 10.2 Modbus settings

Protocol type	RTU (not ASCII)
Parity	Even
Baud	Auto-sensing 1200-115200
Signalling	RS485
Node Address	Factory set to 204. User settable 1-254

### 10.3 General Description

The ICS is a Modbus Slave. That is, it responds only to commands sent to it by the Modbus controller (the Modbus Master). The controller can be a program running on a PC, or a PLC.

The Master periodically sends a Modbus command 'frame' to the ICS node address.

The ICS acknowledges each request with a response frame.

### 10.4 Modbus registers

The Modbus protocol defines many types of information interchange commands ('function codes'). However in order to simplify implementation the ICS only uses one type - the Modbus 'Register'. Conceptually the ICS appears as a collection of Modbus Registers. Each register is numbered.

### 10.5 Modbus Register Numbering

Addresses shown here are those appearing 'on the wire'. Unfortunately some Modbus controllers may translate these addresses to different ones. For example for some controllers the user will need to use 'addresses' starting at 40000 instead of 0.

The ICS uses a few registers from the range 0-124. This allows all registers to fit in a single Modbus frame. Registers can be divided into classes. (See following page).

## Status Registers

These are 'read-only' registers that indicate test results and ICS status. They can be read freely at any time (although test results are only valid after a successful test).

### 10.6 Modbus Register Table

Number	Function	Units	Representation
0	Product ID		Unsigned integer
1	Protocol ID		Unsigned integer
2	Firmware Version	x100	Unsigned integer
3	Hardware Options		Bitmap
4-5	Machine Serial Number		32 bit unsigned integer
6	Modbus Address		Integer
10-17	Test Reference		Array of 16 packed characters
18	Test Duration	S	Unsigned integer
19	Test Format		Integer
30	Status		Unsigned integer
31	Status Flags		Bitmap Unsigned integer
32	LED Levels		Unsigned integer
35	Peak Pulse		Unsigned integer
36	Test Completion		Unsigned integer
37	Flow Indication		Unsigned integer
56-63	Result Codes		Array of 8 signed integers
117-118	Calibration Due		
119-120	Calibration Last		

# REFERENCE

## Modus Registers

All quantities are represented using Modbus registers. Modbus registers are 16 bit (0-65535 decimal or 0-0xFFFF in hexadecimal notation).

## Unsigned Integers

These are simply single modbus registers. Each can take values from 0 to 65535.

They may be simple numeric quantities such as "test time in seconds". They can also be enumerations such as 'result format' where '0' means ISO4406

## Signed Integers

These are used for quantities that may become negative, such as °C.

Signed integers are represented in single modbus registers using the 'twos complement' standard, as usual in computing. If a user-written program incorrectly interprets a signed integer as unsigned, then positive numbers will still be interpreted correctly. However small negative numbers will appear as large positive ones. In particular, -1 appears as 65535 and -2 as 65534.

## 32 Bit Unsigned Integers

Some quantities are (or may become) too large to fit into a single 16-bit register. For example the Test Number could eventually increment to more than 65535. These items are represented using two consecutive registers; the combination makes up a 32-bit integer.

For example, the value of such a 32 bit unsigned integer stored in registers 8-9 may be calculated using the formula:  
 $value = (65536 \times (register\ 8)) + (register\ 9)$

## Bitmaps

Bitmaps are again single 16-bit Modbus registers, but they have a special interpretation.

Each "bit" in the register has a separate function. The most important example is the 'status flags' register (31). Each register bit encodes a separate function, for example 'result valid', 'new result', 'over temperature alarm' etc. In this document bits are numbered starting with bit 0 = least significant bit.

A user programming environment such as a PLC programming system or a high level computer language will normally have functions that allow easy access of individual bit values in a register.

## Arrays

An Array is simply a sequence of objects packed in consecutive registers. For example the “result codes” are in an array of 8 registers. Code[0] is in register 56, code[1] is in register 57 etc.

In the case of an array of 32-bit integers, each element itself takes up 2 registers, so there are twice as many registers used as elements in the array. In the case of the particle counts array, there are 8 particle sizes counted so these are stored in  $8 \times 2 = 16$  registers.

## Packed Characters

These are used to encode the user-settable ‘test reference’ string, used to label each test. Characters are packed two per Modbus register. This will probably not be used in a user-written Modbus program, but in principle the test reference could be set to a different value for each test. The test reference string consists of 16 characters packed into an array of 8 consecutive registers.

## 10.7 Register Functions

### Test Mode

Factory set value: 0

This is the test mode, each bit represents an option.

Each bit of the register encodes one option.

The factory set mode is 0 for all bits, so all the tickboxes are turned off. You may want to turn on bit 8 (disable low flow alarm when clean) if you have a very clean system.

Here are the bit definitions:

Bit	Function	Comment
0	Cycle_Continuous	Continuous Testing
7	Simulate	Produces simulated test results
8	Low-Flow_Clean_Disabled	Prevents spurious low flow alarms on clean systems



# REFERENCE

## 10.8 Status Register

This is read-only register 30. It contains a number (an enumeration) indicating the status of the ICS.

Value	Function	Comment
0	Not Ready	Unit is powering-up, or there is some problem
1	Ready	Ready to start a test (User has not set tests to occur automatically)
2	Testing	Test in progress
3	Waiting	Waiting between tests (User has set a non-zero test interval)
128	Fault Optical	LED failure / sensor blocked / filled with air
129	Fault Flow Low	Flow too low for reliable test (Or fluid is totally clean (no particle counts). Flow alarm can be turned off by user if this is a problem, for example cleaning rigs)
130	Fault Flow High	

## Status Flags Bitmap

This is read-only register 31. It represents the states of various items in a bitmap format.

Bits 0-2 are so that external equipment (for example a PLC/MMI) can display, update and log results intelligently.

Bits 3 and 4 can be used to monitor the test progress.

Bit	Function	Comment
0	Result_Valid	Current result is valid
1	Result_New	New result available
2	Result_Log	Current result should be logged
3	Testing	Test in progress
4	Complete	Test complete

## Fault Flags Bitmap

This is read-only register 28XIV. It represents detected device or installation faults in a bitmap format. The faults are also available as result codes in the status register, however those are transient and may only appear briefly before a new test is started.

The fault bits here remain until the end of the next test (where they may be cleared if the fault has gone).

Bit	Function	Comment
0	Optical Fault	Current result is valid
1	Low-Flow	New result available
2	High_Flow	Current result should be logged

## Result Codes

The test result “codes” use up to 8 registers 56-58.

The interpretation of these result code registers depends on the selected result format.

The various interpretations are listed in the following table:

Register	ISO4406 code
56	$\geq 4\mu$
57	$\geq 6\mu$
58	$\geq 14\mu$

All data, details and words contained in this publication are provided for use by technically qualified personnel at their discretion, without warranty of any kind.

MP Filtri reserves the right to make modifications to the models and versions of the described products at any time for both technical and/or commercial reasons.

For updated information please visit our website: [www.mpfiltri.com](http://www.mpfiltri.com)

The colors and the pictures of the products are purely indicative.

Any reproduction, partial or total, of this document is strictly forbidden.

All rights are strictly reserved

# WORLDWIDE NETWORK

CANADA ♦ CHINA ♦ FRANCE ♦ GERMANY ♦ INDIA ♦ SINGAPORE  
UNITED ARAB EMIRATES ♦ UNITED KINGDOM ♦ USA



PASSION  PERFORM

in @ y f



[mpfiltri.com](http://mpfiltri.com)  
Scan or click me!